

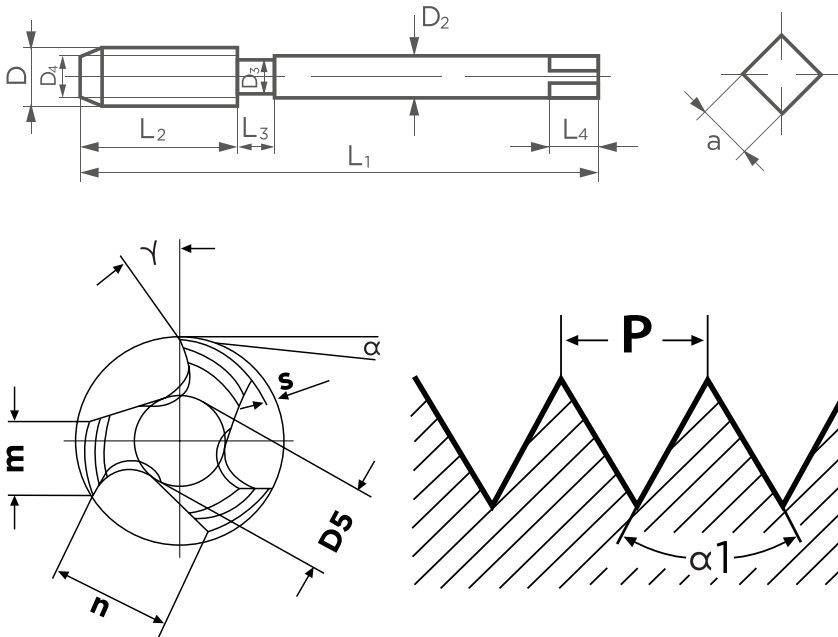

### TEKNISK INFORMATION



D	Nominal diameter
D2	Skaft diameter
D3	Nakke diameter
D4	Punkt diameter
D5	Indvendig diameter
L1	Total længde
L2	Gevindlængde
L3	Nakkelængde
L4	Square længde
P	Gevindstigning
a	Square
m	Land bredde
n	Sporbredde
s	Underskæring (thread relief)
$\alpha$	Underskæringsvinkel (relief angle)
$\gamma$	Spånvinkel
$\alpha_1$	Gevindvinkel

### Gevindansnit på håndtappe, Sæt af 3 stk.

#### ca. 6 ansnit

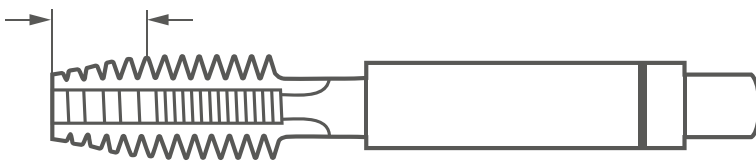

**Nr. 1**  
Spids, 6-8 gevindansnit

#### ca. 4 ansnit

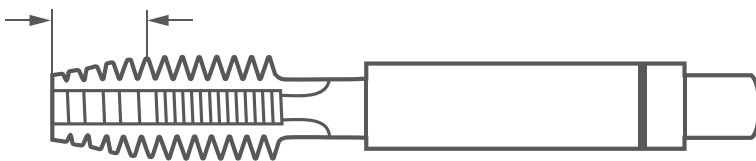

**Nr. 2**  
Mellem, 4-5 gevindansnit

#### ca. 2 ansnit

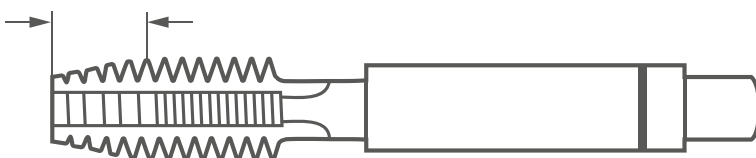

**Nr. 3**  
Bund, 2-3 gevindansnit

## Gvindansnit på håndtappe, Sæt af 2 stk.

ca. 5 ansnit

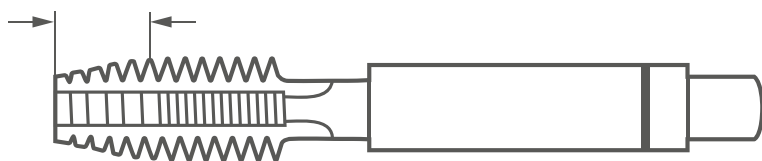

**Nr. 1**

Spids, 5-6 gevindansnit

ca. 2 ansnit

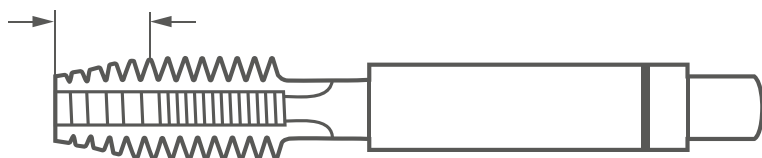

**Nr. 2**

Bund, 2-3 gevindansnit

**SNITTAPPE**  
ALT I GEVINDVÆRKTØJER

